



DEVELOPMENT OF A HIGH CAPACITY THREE HEADED COIL-SPOOL WINDING MACHINE

Beyza Avci¹, Sercan Kavak¹, Figan Dalmis², Serdar Osman Yimaz³, Ibrahim Savas Dalmis^{*3}

¹DOMEKS Machinery A.S. Design Center, Türkiye

²TNKU, Vocational College of Technical Sciences, Electronic and Automation Department, Türkiye

³TNKU, Çorlu Engineering Faculty, Mechanical Engineering Department, Türkiye

ARTICLE INFO

Article history:

Received 5 October 2023

Accepted 10 November 2023

Keywords:

cable, coil, machine design, spool, cable winding

ABSTRACT

Cable packaging machines are machines that can automatically wrap long and thin materials such as wires, cables and pipes into regular packages. These machines play an important role in cable production and save time and labour in the production process. There are many types of cable packaging machines and they have different features, but in general, all of them ensure that the materials are wrapped in the correct size, tightly packed and transported quickly. In the machine designed and manufactured in this study, cables are packed in perforated spool, slotted spool and coil form. The system consists of 7 sections as unloader, traverse unit, dancer, cable winding heads, spool feeding, pliers group and main control panel. In the designed and manufactured machine, the number of cable winding heads was increased to 3 for the first time and the lost time during the cable winding process was minimized. In the research, the performance of the designed and manufactured machine was tested. As a result of the experiments, it was determined that the machine winds 10-12 coils/min at a cable length of 16,5-25 m and 4,5-5 spools/min at a cable length of 100 m.

© 2023 Journal of the Technical University of Gabrovo. All rights reserved.

1. INTRODUCTION

Developments in the construction industry, the increase in the world population, the growth of the industry, the production of new and more advanced devices, developments in the automotive sector, the increase in demand for renewable energy sources worldwide and the need for electricity at every point of households have led to an increase in demand for installation cables. Since medium and high voltage electricity transmission is over long distances, the production, transportation and sales of these cables are also in high quantities. Today, installation cables are mostly sold in packages of 100 m. The desire of individual users to purchase only the amount of cables suitable for their needs reveals the need to pack the cables in short quantities such as 5 m, 10 m, 15 m. To meet this demand, cable manufacturers and sellers also make small-sized and dimensioned cable winding.

Cables are offered for sale in different methods according to market habits. Commonly used methods for sale are in the form of spools and coils. Cables wound in the form of spools are wound on spools made of plastic, cardboard or wood in the desired length and stretched in the stretching section and offered for sale. Cables offered for sale in the form of coils do not have any carrier. The cable is usually wound on a cylinder made of metal and there are two methods for the cable to maintain its shape after winding. One of them is the stretching method. The cables

are wound on a cylinder made of metal and stretched after the desired length is obtained and cut. After the stretching process, the metal cylinder is removed from the cable, the cable coil, which continues to maintain its shape, is placed in nylon shrink to protect it from external factors and the packaging process is completed. Another method is the rope wrapping method. After the cable is wrapped in the cylinder made of metal, the metal cylinder is removed from the cable. The coil is taken with the help of pliers so as not to distort its shape and brought to the rope wrapping section. The rope is wound in the desired number according to the customer's request and the packaging process is completed.

Various researches have been carried out on automatic packaging and automatic cable packaging machines, which are widely used in daily life.

A paper by Ding et al. (2020) introduces this device to meet the specific requirements of space missions, such as a large propulsion output, large cable displacement and high reliability. The cable organizing device enables the cables to be wound layer by layer on a crane. The redundant motor assembly ensures the normal movement of the mechanism when a motor fails and can provide more torque than a single motor. A prototype of the proposed cable winding device has been manufactured and experiments have been conducted to verify the performance of the device [1].

Hultman (2022) introduces a new concept for automatic stator cable winding of rotating electrical machines. The

* Corresponding author. E-mail: idalmis@nku.edu.tr

use of this concept could potentially lead to savings in cycle time and assembly cost compared to manual or lower volume conventional automation. However, in its current form, it is not possible to compete with existing high-volume conventional winding automation for smaller machines. Future experimental work is expected to focus on the use of larger winding cables and special machine designs, providing greater robustness and optimization [2].

The aim of the study by Hultman and Leijon (2017) is to present and validate further developments in the presented method for robotized cable winding of the Uppsala University Wave Energy Converter generator stator. In the study, the cable preparation consists of three parts: feeding the cable from the drum, forming the cable end and cutting the cable. Previously, these operations were performed manually and only used with small cable drums, so the robot cell had to be stopped frequently. The new equipment is reported to have been tested on an experimental robot stator cable winding assembly. Through the experiments, it was confirmed that the equipment can realize a fully automatic and robust cable preparation [3].

In the study by Wu et al. (2019), an automatic cable winding system was established to solve the problem of low degree of mechanical automation. This system is innovatively designed based on machine vision and automates manual cable placement and arrangement processes. This system obtains the target coordinates by processing the video image sets collected by an industrial camera and controls the rotation of the mechanical arm through a PC. In this way, the degree of automation is increased. To find the targets, a target recognition algorithm based on Hu invariant moment and multi degree of freedom neural network (MDOFNN) is designed. This algorithm recognizes the contour information of the target and obtains the coordinates of the target by ellipse fitting. The target recognition algorithm is experimentally evaluated by comparing it with a support vector machine (SVM). Results show that the recognition rate of this algorithm is higher compared to SVM, which is suitable for industrial control. This work represents an innovative approach to solve the problem of mechanical automation and improve the degree of automation of an automatic cable winding system [4].

The study by Hultman and Leijon (2018), together with the detailed presentation of fully automated stator cable winding assembly equipment, represents an important step forward that could provide potential cost savings in future manufacturing processes and requires further reliability studies [5].

A paper by Wen and Stapleton (2008) presents the work on tension control and introduces the design and testing of a prototype system that reduces tension variations through the use of fluidized muscle. The results show that the proposed system provides better performance by increasing the winding speed [6].

The invention made by Öztürk and Özbaran (2014) relates to an automatic machine consisting of a winding head on which the cable is wound in sequence at the desired length, a knife mechanism that performs cutting, holding and dragging operations, a hold-turn mechanism that enables the cable package to be held and centered, a strap throwing machine that enables the cable package to be fixed by throwing a strap, a pressing mechanism that ensures that the cable end remaining outside the package is kept to a minimum and an automatic machine that enables

the production to be faster, higher quality and to produce package length in accordance with the standards [7].

The invention made by Öztürk and Özbaran (2010), is a cable winding machine that performs coil and spool type winding operations in the same machine, and it is characterized in that it consists of a winding station that performs both coil and spool winding with at least two winding heads symmetrical to each other in order to perform the winding process, channeled spools for use in the spool form winding process and head fasteners for use in coil winding mode and coil heads that can shrink and expand. stretch film made of polyethylene, PVC, etc. to fix the end of the wrapped material outside the spool or coil and at least two stretch wrapping mechanisms and at least two rotational gripper pliers that enable the stretch film to be fixed by wrapping it around the spool or coil and at the same time holding the last end of the material cut in the spool or coil during this process [8].

The invention of Öztürk and Özbaran (2007) is a cable packaging machine in which both coil type and spool type packaging can be performed by means of the same mechanism. Coil type and spool type wrapping operations are carried out by means of coil head and spool wrapping heads, which are intertwined with each other in a single wrapping head and which perform wrapping operations according to the selected mode [9].

Literature researches have shown that the majority of academic studies have been conducted on winding machines. In this study, a 3-Headed Spool-Coil Winding Machine with increased capacity was designed and manufactured in order to increase the industrial production capacity of cable winding in the form of Coil and Spool.

2. MATERIAL AND METHOD

This study was carried out to design a 3-headed spool-coil winding machine with increased capacity. The general flow chart of the cable packaging process is presented in Figure 1. The developed 3-headed spool-coil winding machine is designed in such a way that a different process is performed on each of the winding heads and none of the heads are idle. It has the capacity to wind 10-12 pcs/minute coils and 7-8 pcs/minute spools depending on the quantity of the cable to be wound.

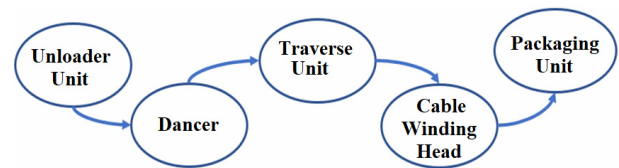

Fig. 1. General flow chart of cable packaging process

Cable Packing Machine Components

The position and general components of the 3-headed spool-coil winding machine, which was designed and manufactured in the study, on the production line are presented in Figure 2.

Unloader Unit

After all the components of the cable winding line are adjusted together with the electrical and air sources, the machine is ready to be fed with cable. The movements of the unloading unit will be made from the unloader control panel. From the unloading unit, the cable is fed to the Dancer section according to the cable quantity to be wound.

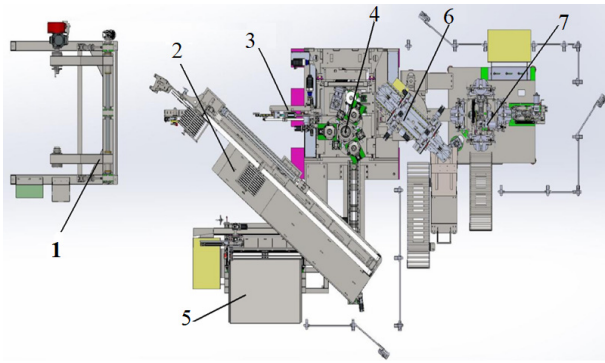

Fig. 2. Machine General View 1. Unloader Unit 2. Dancer 3. Traverse Unit 4. Coiling Section 5. Spool Feeding Unit 6. Packaging Unit 7. Main Control Panel

Dancer

The Dancer unit is used to accumulate the cable to feed the winding process continuously. The cable accumulation takes place with two groups of parallel spools. The first one is static and the cable loading starts from here, the second one moves forwards when loading the cable and moves backwards when retracting the cable to pass the cable to the winding unit. The movement of this spool unit is realized by a belt connected to the piston. The second spool group is connected to the Dancer by linear guides on rails.

Traverse Unit

The traverse unit is used to guide the cable during the winding process. This mechanism moves up-down and right-left to ensure that the cable is crimped in place. The machine's software automatically adjusts the speed and type of these actions. Only the coil diameters and the coil winding speed per minute must be entered by the machine operator. The traverse unit takes the cable to the wing head before winding. And the coil keeps going up and down, right and left. There is a pipe in the traverser. This pipe receives the cable. During the winding process, this pipe is used to guide the cable. At the end of the winding process, there is a pneumatic arm that pushes the product (coil or spool) to the travelling belt.

Coiling Section

The main operation of the up winding head (Fig 3.) is to wind the cable by moving the winding parts in its center, driven by a servo motor. This servo motor is connected to a special trigger gear with a belt to pass the rotation to the winding head. The winding speed is adjusted by this servo motor by entering data from the control panel.

The Up Winding Head can be opened and closed at the beginning and end of the winding process to put the end of the cable underneath to catch and remove the cable spool when the winding process is finished. In order for the Rewinding Unit to catch the end of the cable, there are special mechanism groups that press and hold the end of the cable until the end of the winding.

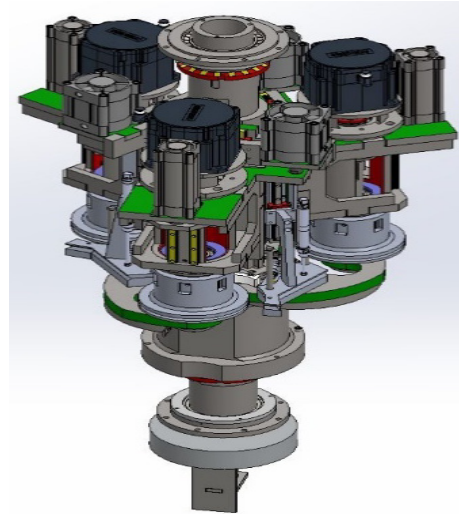

Fig. 3. Coiling Section

Spool Feeding Unit

The Spool feeding conveyor is used to feed the winding head to the spool when the machine is running in spool mode. As the hole on the spool must be in a certain position, the spool must be placed in the spool feed magazine. The conveyor automatically picks up the spools and pushes them between the take-up arms. The spool holding arm consists of two parts; the first one is to take the free spool from the conveyor and move it in the second arm zone, the second one is to take the free spool from the end zone and place it on the winding head.

Spool Feeding Unit

It is used to take the completed spool and coil from the winding head and to leave them to the packaging unit or ready product section by rotating.

Packaging Unit

After the winding process is completed, the cable taken with the help of pliers is transferred to the cable packaging department in line with customer demand and packaged with methods such as rope wrapping, stretching, etc.

Main Control Panel

The developed 3-headed spool-coil winding machine with increased capacity is controlled through a touch screen operator panel (HMI-Human Machine Interface) and PLC(Programmable Logic Controller).

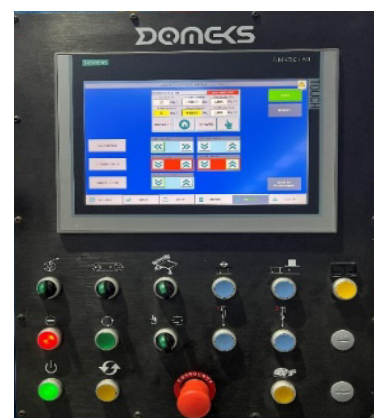

Fig. 4. Main Control Panel

Errors occurred during the operation of the line are displayed on HMI (Fig 4.). SIEMENS brand PLC was used to control and automation of the machine. The Totally Integrated Automation (TIA) Portal is used to design PLC program and HMI displays.

3. RESULT AND DISCUSSION

Each head of the designed machine performs a different process and none of the heads are idle. For coil-shaped cable winding, firstly, the cylinder on the first head goes down. The cable is fed on the cylinder on the head by the traverse. After the cable is fed, the head rotates 120o without cutting the coiled cable, and the cable is cut when the cylinder in the second head in front of the traverse comes down.

While the remaining part of the cut cable is held with the help of a pliers, the wound cable is held with the help of a lever connected to the piston. The head rotates around itself and winds the remaining cable. After the remaining cable is collected, the heads rotate 120o again and the coil, whose winding process is completed, is taken with the help of forceps. The received coil is stretched or rope wrapped according to customer demand. These processes continue non-stop for each head. There are two types of spools, perforated spools and slotted spools in the cables to be wound in the form of spools. In the spool-shaped cable winding process, the spool is fed to the head first. The spool fed head rotates 120o and comes in front of the traverse. For perforated spools, the traverse pipe approaches the hole of the spool and some cable is fed into the hole of the spool. The knife mechanism inside the spool holds the cable entering through the hole, the head starts to rotate and the cable winding process starts. After the winding process is finished, the head rotates 120o and comes to the stretch wrapping section and the cable is cut with the help of the knives in front of the traverse. After the cable is cut, the head rotates around itself in the stretch head and both the stretching process takes place and the cable remaining after the cutting process is wound on the spool. After the stretching process is completed, the spool is taken with the help of pliers and the packaging process is completed. This process continues non-stop for all perforated spools.

For slotted spools, the initial cable feeding process is the same as for perforated spools. After the cable is held with the help of the knife in the slotted spool, the winding process starts. After the cable winding process is completed, the head rotates 120o and comes to the stretch throwing section. Unlike perforated spools, the cable cutting process is carried out with the help of a knife inside the spool. When the spool turns to the stretch section, one end of the cable is in the spool in the stretch section and one end is in the traverse section. The traverse comes to the appropriate position and places the cable that has not yet been cut into the slit in the spool and is held and cut with the help of the knife inside the slotted spool. The held part of the cable starts to be wound on the new spool. The spool in the stretch head rotates around itself and both wraps the increasing cable and completes the stretch process. The packaging process is completed by removing the spool with the help of pliers.

The developed PLC-based control system is modular and flexible for new system requirements. The control of system is carried out through analog/digital inputs and outputs obtained from analog/digital modules. The rotating speed and output torque of servo motors are controlled by

PLC and HMI. The operation of each driver and module was individually checked, and the system tests were conducted successfully.

The parts of the designed and manufactured 3-headed spool-coil winding machine with increased capacity are shown in Figure 5 and Figure 6.

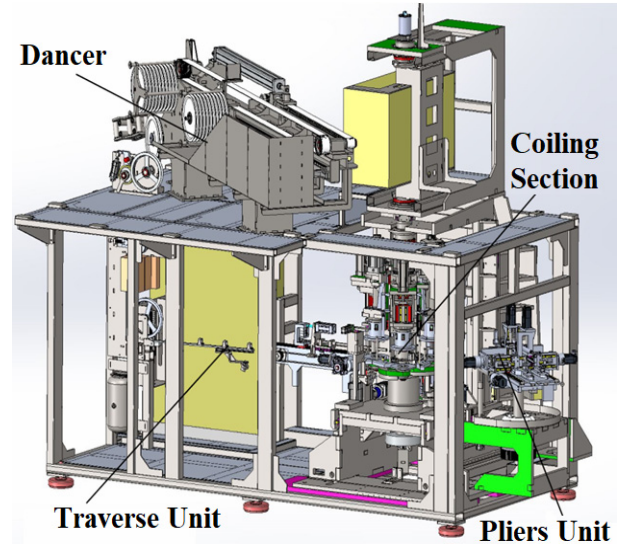

Fig. 5. Sections of the 3-headed spool-coil winding machine with increased capacity

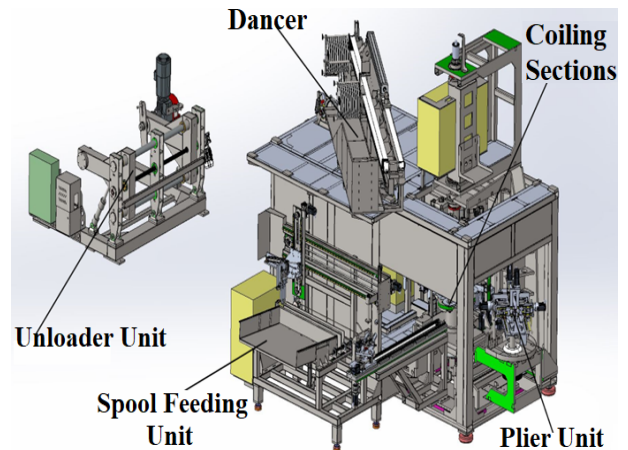

Fig. 6. Sections of the 3-headed spool-coil winding machine with increased capacity

The performance of the machine designed and manufactured in this research was tested at the design center laboratories of Domeks Makine company. As a result of the experiments, the machine has been tested in short lengths such as 16,5 m and 20 m and in long lengths such as 100 m in coils with a cable length of 100 m. The comparison of the results of the trials with the existing machines are given in Table 1 and Table 2.

Table 1 Winding speeds of the machines and the number of coils wrapped

Machine Name	Winding Speed (m/min)	Cable Length (m)	Number of Coils (pcs)
High-Capacity 3-Headed Spool-Coiling Machine	800	100	8
	200-250	25	10
	180-200	16,5	11.5-12
Machine 1	700	100	7

	100-125	25	4-5
	60-90	16,5	4-5
Machine 2	400-500	100	4-4.5
	-	25	-
	-	16,5	-

Table 2 Winding speeds of the machines and the number of spools wrapped

Machine Name	Winding Speed (m/min)	Cable Length (m)	Number of Spool (pcs)
High-Capacity 3-Headed Spool-Coiling Machine	450-500	100	4.5-5
	-	25	-
	-	16,5	-
Machine 1	-	100	-
	-	25	-
	-	16,5	-
Machine 2	400-500	100	2.5-3
	-	25	-
	-	16,5	-
Machine 3	400-500	100	2.5-3
	-	25	-
	-	16,5	-

Some of the existing machines designed and manufactured by the company are named in this study Machine 1, Machine 2 and Machine 3. Machine 1 has 2 winder heads and performs spool winding. Machine 2 has double winder head and performs both spool and coil winding. Machine 3 has 2 winding heads and performs coil-shaped cable winding. The designed 3-headed spool-coil winding machine with increased capacity has 3 winding heads and performs both coil and spool winding. The designed machine and the existing machines are compared in terms of the number of cables wound in coil form and the number of cables wound in spool form in short and long quantities.

The newly designed high-capacity 3-headed spool-coiling machine, features 3 winding heads and can perform both spool and spool coiling. The designed machine and the existing machines have been compared in terms of short and long cable lengths, the number of cables wound in spool or spool form, and energy consumption.

As a result of the experiments carried out:

- Higher winding speeds can be achieved in the designed machine and by this means, 2 times more coil form cable can be wound in a short length of cable compared to the existing machines.

- It was observed that the 3-headed spool-coil winding machine with increased capacity could wind 8 cables in coil form with a cable length of 100 meters and a winding speed of 800 m/min.

- It was examined that the 3-headed spool-coil winding machine with increased capacity was able to wind 4.5-5

spools at a winding speed of 450-500 m/min and a cable length of 100 meters.

4. CONCLUSION

While the packaging of short-length cables was done by an operator at a speed of 2 pieces/min in manual machines, this speed was increased up to 6-7 pieces/min with the new automatic machine, but the lost time could not be completely eliminated in the previous machines. In this study, the design of a 3-headed spool-coil winding machine with increased capacity to minimize the lost time in feeding, winding and collecting sections was carried out.

In the designed machine, the capacity was increased by minimizing the lost time during the winding process by means of the increased winding station. At the end of the design, the number of coils and spools wound on the machine were measured and compared with the existing machines. When compared with the existing machines, it was observed that the machine designed for short-length coil winding (16.5-25 m) winds 2 times more coils than the existing machines.

ACKNOWLEDGMENT

This study has been supported by DOMEKS Machinery Inc. Design Center.

REFERENCES

- [1] Ding, X., Xiao, H., Yang, Q., Li, L., & Xu, K. (2020). Design and analysis of a cable-winding device driving large deployable mechanisms in astrophysics missions. *Acta Astronautica*, 169, 124–137.
- [2] Hultman, E., (2022), Introducing robotized stator cable winding to rotating electric machines, *Machines* 2022, 10, 695. <https://doi.org/10.3390/machines10080695>
- [3] Hultman, E., Leijon, M., (2017), Automated Cable Preparation for Robotized Stator Cable Winding, *Machines*, 5(2), 14. doi:10.3390/machines5020014
- [4] Wu D., Hua L., Qiang Y., Gu J., Jiang L., Zhao J., (2019), Research and implementation of automatic cable winding system based on machine vision, 2019 34rd Youth Academic Annual Conference of Chinese Association of Automation (YAC), Nantong, Jiangsu, China.
- [5] Hultman, E., & Leijon, M. (2018). Robotized stator cable winding. *Robotics and Computer-Integrated Manufacturing*, 53, 197–214. doi:10.1016/j.rcim.2018.04.009
- [6] Peng Wen, Stapleton, C., & Yan Li. (2008). Tension control of a winding machine for rectangular coils. 2008 10th International Conference on Control, Automation, Robotics and Vision. doi:10.1109/icarcv.2008.4795843
- [7] Öztürk, H., Özbaran, D., (2014), Kablo paketleme için otomatik makine, Türkiye, Patent No 2014/15805
- [8] Öztürk, H., Özbaran, D., (2010), Kangal ve makara formunda kablo sarımı yapan makine, Türkiye, Patent No WO 2011/093806 A2
- [9] Öztürk, H., Özbaran, D., (2007), Cable packaging machine., Türkiye, Patent No WO2009/045181(A1)