



FEATURES OF DETERMINING THE CONVERSION OF ENERGY IN HYDRAULIC SYSTEMS

Dmytro Kostiuk*, Igor Nochnichenko, Alona Murashchenko, Oleg Jakhno
National Technical University of Ukraine "Igor Sikorsky Kyiv Polytechnic Institute", Ukraine

ARTICLE INFO

Article history:

Received 28 September 2022

Accepted 29 November 2022

Keywords:

hydraulic system, energy conversion, transfer phenomena, diffusor, damper

ABSTRACT

The analysis of the processes of transformation of kinetic energy in various types of devices providing both stabilizations of the flow and partial damping of energy is carried out. In the analysis, the features of the flow of a viscous fluid in diffusers, pulsation dampers, and shock absorbers are considered. In addition, it has been shown that for electrically conductive liquids, the transverse magnetic field method can be used. The materials of the analysis can be used to describe energy transport phenomena in liquids.

© 2022 Journal of the Technical University of Gabrovo. All rights reserved.

1. INTRODUCTION

In many cases, when designing hydraulic systems, it becomes necessary to absorb the energy associated with the operation of the pump and drive. In some cases, when using these machines in a stream, speed and pressure pulsations may occur that adversely affect the operation of the hydraulic system. The cause of such pulsations or the degree of flow instability can be not only pumps and hydraulic drive, but also external influences on the flow associated with cavitation, vibration, etc. To eliminate these shortcomings and obtain a stabilized flow, various types of devices can be used, in particular diffusers, pulsation dampers, and dampers. In addition, if the liquid is electrically conductive, then the damping of energy and vortex formation can be carried out under the influence of a magnetic field, in particular ponderomotive forces.

2. EXPOSITION

The simplest example characterizing the transformation of energy can be an example of a flow in a hydrodynamic initial section. The destabilization of the flow in this case is determined by the influence of inertia forces from convective acceleration. The flow in the initial section is described in several works, including those by Schiller, Tyabin, and Schlichting [1]. The description of such a flow can be presented from the standpoint of the theory of the boundary layer. When a viscous fluid flows at the channel inlet, a boundary layer is formed near the channel wall, in which the flow is decelerated. At the same time, the movement in the core of the flow is accelerated. The thickness of the boundary layer along the channel increases, while the thickness of the core decreases. Thus, a velocity diagram is formed in the initial section, and part of the energy is spent on its formation. This explains that the

pressure drop in the initial section is slightly higher than in the section of the stabilized flow. The study [2] shows a possible change in pressure drop.

3. FLOW IN THE DIFFUSERS

A similar picture, with some approximation, can be presented for the flow of liquid in a diffuser, where the nature of the flow is also affected by the opening angle of the diffuser. Targ's study [3] shows how the velocity diagram is deformed (Fig. 1).

Analytical studies show that when a liquid moves through a diffuser, cases of liquid flow can be observed both in the direction of pressure drop and in the direction of pressure increase. It depends on the value of P . Separated flows can also be observed in the diffuser. Depending on the value of P_a , the separation point can move, with increasing P_a approaching the inlet section. The results obtained in the work give flow patterns that are qualitatively very well compatible with what should take place in the relevant cases according to the general theory of the motion of a viscous fluid.

4. PRESSURE PULSATION DAMPERS

Similar energy conversions can be used to reduce pressure and velocity pulsations in hydraulic systems. The issues related to energy conversion, namely the damping of pulsations, are quite fully described in [4] where various types of pulsation dampers are presented, which allow stabilizing various types of flows, including non-stationary ones.

In order to reduce the amplitudes of pressure pulsations in the system, in addition to active methods that interfere with the noise source itself, passive reflective pressure pulsation dampers are used. The principle of operation of

* Corresponding author. E-mail: dvkostyuk@gmail.com

these dampers is based on the interference of the pressure wave coming from the pump with the pressure wave reflected from the damper and traveling in the opposite direction. The diagrams of the analyzed dampers are shown in Fig. 2 with the characteristic dimensions marked to

ensure maximum efficiency in the process of reducing the amplitudes of pressure fluctuations. These dimensions were determined on the basis of simplified mathematical models developed for an ideal liquid.

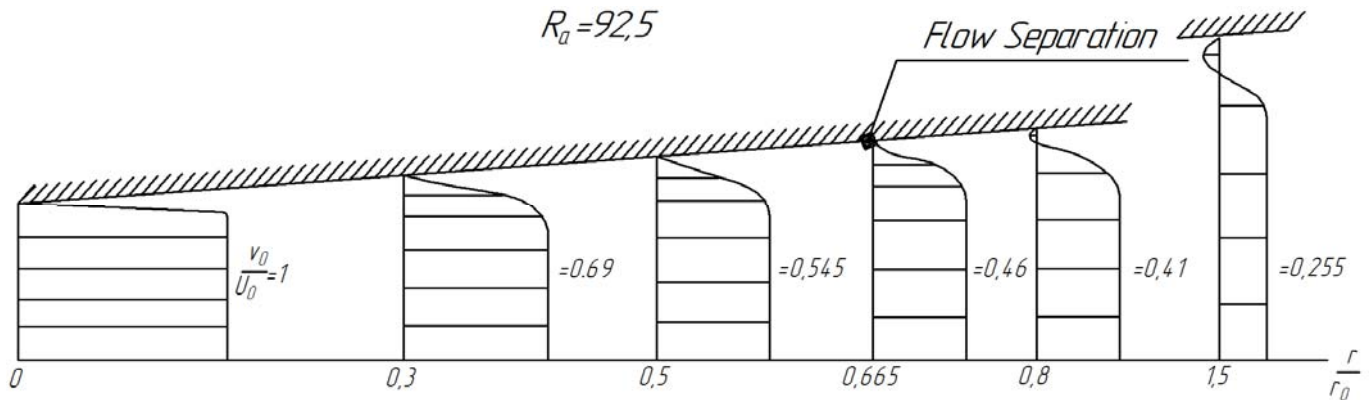

Fig. 1. Velocity profiles in the diffuser [3]

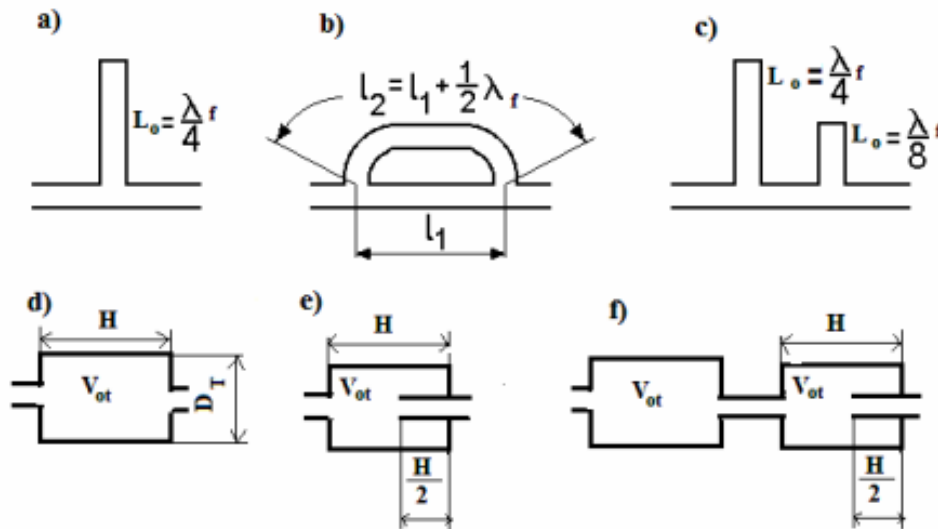

Fig. 2. Types of passive pressure pulsation dampers [4]

5. HYDROMECHANICAL DAMPERS

Dampers have received great practical application allowing them to convert kinetic energy into pressure energy. The design of one of the damper types is shown in fig. 3.

The damping of oscillations during damping in the considered case is related to thermal energy processes. Thus, based on the energy balance, it is possible to characterize damping problems. Let us consider in more detail the nature of the transfer phenomenon and analyze the influence of the transfer coefficient on the example of a hydraulic shock absorber.

The kinetic energy of the liquid jet at the exit of the throttle system is usually the main part of the total energy, which is equivalent to the pressure drop across the piston, which is equivalent to the pressure drop across the piston. The dissipation of energy within the throttling system depends on the design of the valve-throttle unit. In turn, it is explained by shock losses at the entrance to the throttle system and friction losses in the walls of the throttle system channels, and finally, friction between the layers of the

liquid, causing the heating of the liquid. In the general case, the presented requirements are fulfilled from the conditions of similarity, which are reduced to the ratio of the forces of inertia, gravity, friction when applying the similarity criteria of Euler, Froude, Reynolds.

The transformation of energy in the considered system of the car vibration protection unit is presented in fig. 3.

Damping is achieved due to the passage of liquid through calibrated channels and throttles of the valve-throttle unit: "compression" (solid arrow) and "rebound" (dashed arrow). Both valves are in the piston, and the cylinder acts as a body. During translational movement, mechanical energy is transformed into hydraulic energy with subsequent dissipation into the environment. Hydraulic energy is transformed into thermal energy due to the loss of pressure in local resistances of circuit elements following Bernoulli's equation. As can be seen from fig. 3 working processes of the vibration protection unit can be represented through transfer functions, as a characteristic of energy transformations.

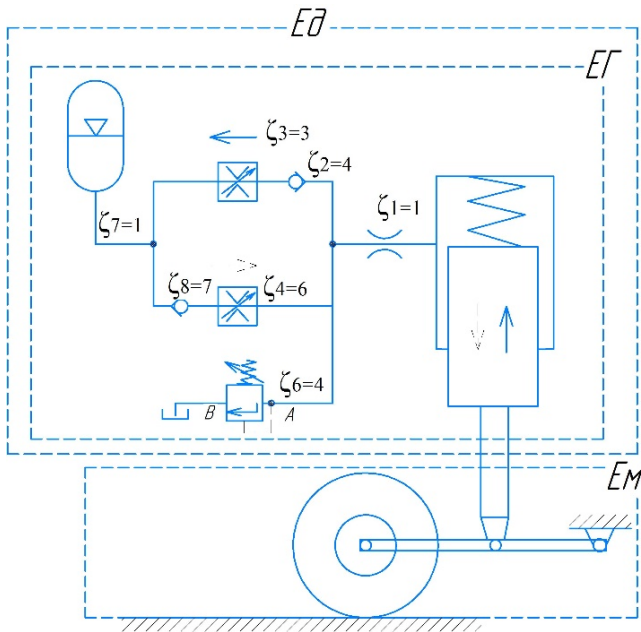

Fig. 3. Structural scheme of the damper unit with the classification of energy transformations

The function of the transfer of kinetic energy is related to the laws of conservation of energy of the amount of motion and determines the operating characteristic of the shock absorber, namely its resistance force.

In many cases, the transfer process can be described by appropriate systems of equations: mass, heat, momentum, characterizing the properties of working fluids, thermal conductivity of material elements, for example, related to the stress tensor and heat flow, equations of motion, energy transfer, heat transfer.

It should be noted that for electrically conductive liquids, an effective method of flow deceleration is the

method of applying a transverse magnetic field. In the works of Regierer, Kallis, as well as the study of Povh [5], it is shown how vortex damping and flow deceleration are achieved. In this case, the assessment of such an influence can be carried out not only using the Reynolds number, but also the Hartmann criterion.

6. CONCLUSION

The presented methods of flow stabilization can be described by the corresponding equations of motion and analyzed based on energy transfer processes, in particular, following the methods described in the works.

Dissipative processes are key in damping tasks, which are significantly related to mechanical energy losses, part of which is transformed over time into hydraulic energy of fluid movement according to the criteria $Eu=f(Fr;Re)$.

The presented approach for energy conversion can be effectively used in the working processes of dampers, receivers and other energy quenchers.

REFERENCES

- [1] Shlihting G. Teorija pograničnogo sloja (Boundary layer theory) [Tekst] / G. Shlihting. – M. Nauka (1974) p.712
- [2] Jahno O. Gidrodinamičeskij nachal'nyj učastok (Hydrodynamic initial section) / O. M. Jahno, V. S. Krivosheev, V. M. Matiega // Chernovci, «Zelena Bukovina» (2004) p.200
- [3] Targ C. M. Osnovnye zadachi teorii laminarnyh tečenij (Main tasks of the theory of laminar flows) M. Nauka (1961) p.370
- [4] Kudźma Z. Tłumienie pulsacji ciśnienia i hałasu w układach bhydraulicznych w stanach przejściowych i ustalonych. Oficyna Wydawnicza Politechniki Wrocławskiej / Damping of pressure and noise pulsation in bhydraulic systems in transient and steady states. Publishing House of the Wrocław University of Technology, Wrocław (2012)
- [5] Povh I. L. Tehničeskaja gidromehanika (Technical fluid mechanics) / I. L. Povh. M. Mashinostroenie (1976) p.504