



MODELING OF SCRUBBER FOR CLEANING INDUSTRIAL GASES

Valerii Aftaniuk^{1*}, Vladislav Spinov²

¹National University "Odessa Maritime Academy", Odessa, Ukraine

²Odessa National Polytechnic University, Odessa, Ukraine

ARTICLE INFO

Article history:

Received 25 September 2018

Accepted 20 November 2018

Keywords:

scrubbing technology for thermal power, solid-state models of scrubbers, cleaning polluted emissions removed from heat energy objects

ABSTRACT

In this paper, a numerical simulation of a scrubber with a vortex plate is presented for the purification of contaminated gases emitted to the atmosphere in industry. To simulate aerodynamics, a solid-state scrubber model has been developed. The solid model of the scrubber is made in the form of "assembly" and allows modeling both the whole apparatus and its individual elements. In the scrubber model calculations, different materials can be used for each element (simple carbon steel, alloy steels, ceramics, etc.). This allows you to optimize the production of the scrubber, depending on the requirements of reliability, durability and cost. The simulation results allow selecting and optimizing the design and technological parameters of the scrubber. The developed model can be used as a separate unit in larger models of purification systems, which include several types of scrubbers for various industries.

© 2018 Journal of the Technical University of Gabrovo. All rights reserved.

INTRODUCTION

The problems of cleaning harmful emissions from process equipment remain relevant for most industrial enterprises.

The most common environmental pollutant in almost any industry is dust, which is formed in the processes of crushing or moving a solid raw material.

The main type of gas cleaning equipment used in heat and power industry is "wet" scrubbers. Using scrubbers, about 50% of all flue gases generated at thermal power plants are cleared [1]. In industrial cleaning systems, a "wet" scrubber is the main unit of gas cleaning.

Reduce pollution of the environment by industrial emissions through the development of effective gas cleaning facilities.

One of the ways to increase the efficiency of dust collecting apparatus is to improve the design of scrubbers, in order to ensure maximum cleaning efficiency with minimal energy consumption.

For the purification of industrial gases, a scrubber design with a vortex plate is proposed [2] (fig. 1).

The vortex plate of the scrubber (Fig. 2) is the main element in the apparatus on which the cleaning efficiency depends. A vortex flow is formed in the vortex plate with the help of axial-vortex swirlers (fig. 1), to improve the circulation of the liquid in the bump, a special channel with holes is formed.

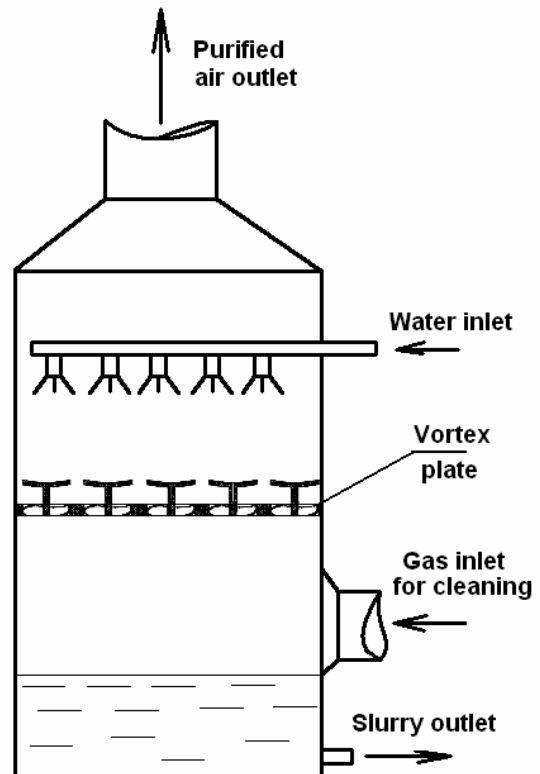

Fig. 1. Schematic diagram of the scrubber

The execution of vortex elements in the form of axial-blade vortex allows to achieve a high degree of twisting of

* Corresponding author. E-mail: valera2187@ukr.net

flows and formation of foam, which creates a stable uniform filtering layer of foam [3].

The filtering foam layer can be adjusted using the height of the swirl element baffle.

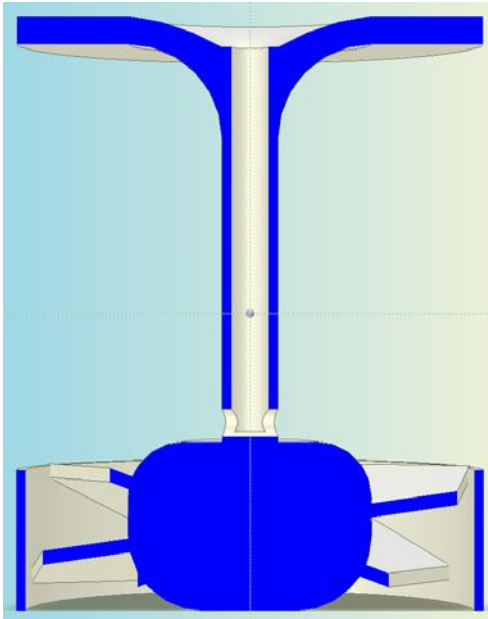

Fig. 2. Geometrical model (cut) of the element of the vortex plate of the scrubber

Optimization of the design and design of the scrubber was carried out using solid-state computer models. In this paper, the software complex Solid Works Flow Simulation was used to numerically study the hydrodynamics of flow and filtration in a scrubber.

The adequacy and accuracy of the mathematical model is determined by the totality of the factors considered and the assumptions made.

The mathematical model of gas flows in a scrubber is based on the Navier - Stokes equations, the equation of continuity, the law of conservation of energy [4].

Modern numerical methods for solving the Navier-Stokes equations make it possible to calculate three-dimensional problems in computational domains that accurately reproduce the geometry of the object of investigation, with a fairly accurate setting of all input parameters [5].

EXPOSITION

The aim of the work is the development of a geometric and mathematical model of a scrubber for the purification of polluted gases from an industrial enterprise.

The aim of the study is to develop a geometric and mathematical model of a scrubber for cleaning contaminated gases removed from heat and power equipment in industrial plants or thermal power plants.

For the simulation, a scrubber [1] with dimensions a:

- diameter 0.85 m;
- the overall height of the device is 3,54 m.

In the middle part a vortex plate is installed at a distance of 0,5 m (in height) from the inlet branch pipe of the apparatus. There are 163 elements in the vortex plate (fig. 2).

The cycle of the scrubber operation includes the flow of gas from the inlet through the vortex plate to the outlet to the atmosphere. The vortex plate is irrigated with liquid

(water). During the interaction of the liquid and the gas to be purified, a foam (porous) layer in which the gas is purified is formed on the plate.

To simplify the mathematical model, the following assumptions are made:

- the stationary problem is solved;
- gas is considered as an ideal incompressible gas;
- the effect of scrubber walls on the movement of gas is not taken into account;
- calculations of aerodynamics and filtration are carried out without taking into account the irrigation of the scrubber with water.

At the entrance to the scrubber, the speed, mass flow, pressure and temperature of the gas were set. The output was atmospheric pressure.

In the process of modeling the aerodynamics of gas flows in a scrubber, it is necessary to find the distribution of gas velocities, particle trajectories and filtration efficiency in the apparatus.

The geometric model of the scrubber (fig. 3) is built in Solid Works in the form of an assembly and consists of a number of objects: the inlet branch, the lower part of the casing, the vortex plate, the device for feeding water to the plate of the upper part of the casing.

Then, the geometric three-dimensional model was imported into the software package Flow Simulation (Figure 4), in which the calculation area and grid are constructed, the materials are assigned, the initial conditions, boundary conditions, the solver setting, saving the project for its further repeated use, starting the calculation and obtaining results in a visual form using a color legend.

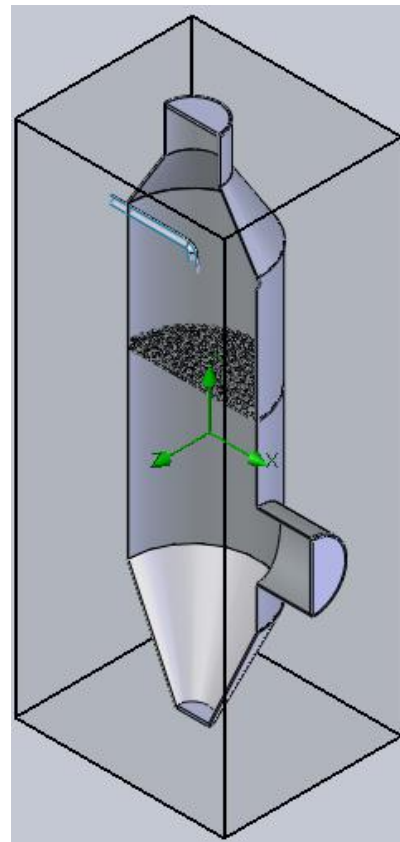

Fig. 3. Scrubber section with calculation area

Modeling with the help of Flow Simulation has made it possible to identify the rational mode of scrubber operation

by constructing mathematical models of velocity fields and particle trajectory fields.

Studies of the scrubber aerodynamics were carried out for various aerodynamic loads. During the simulation, the gas flow rate varied from 1 m³/s to 3 m³/s, which corresponds to the operation modes of the apparatus under production conditions.

Analysis of the gas trajectories shows that a part of the incoming stream deviates from the main direction (towards the filtering layer) forming the developed vortex flows in the lower part of the scrubber.

To improve the aerodynamics of the scrubber in the lower part of the apparatus requires the installation of a special bump cone.

At the next stage of the research, the filter capacity of the scrubber and the calculation of particle trajectories were studied on the model.

To model the filtering layer of the foam, an additional element "foam layer" was created and its characteristics (porosity, thickness, etc.) were set. Element "foam layer" was installed on the vortex plate.

When modeling the filtration in the scrubber and particle trajectories, the particle size and mass flow of particles, the particle material (quartz) were set.

After performing the calculations, it is possible to evaluate and plot the graphs of the density, pressure, and gas velocity changes in the scrubber. In addition, the use of the visualization of trajectories allows you to display the trajectories of the motion of solid particles, depending on their size.

The simulation results (fig.5) allow to determine the uniformity of the distribution of particles along the filter surface of the apparatus, as well as the fractional efficiency of gas purification from solid particles.

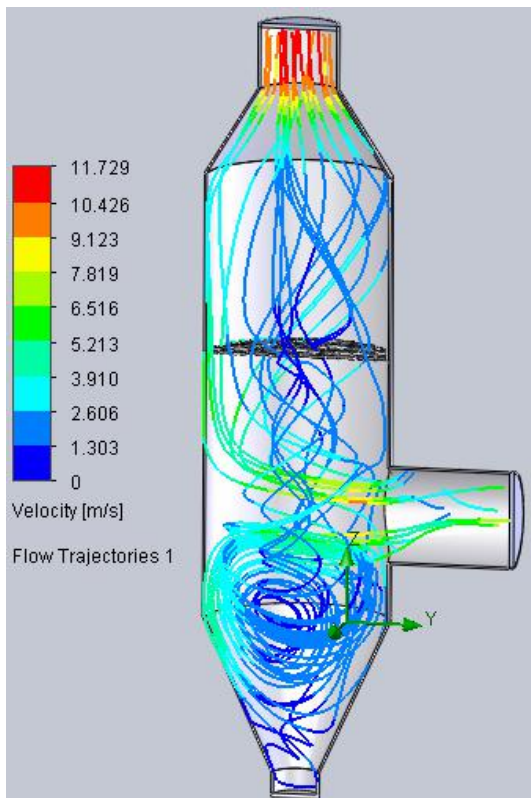

Fig. 4. The results of an investigation of the scrubber aerodynamics at a gas flow rate of 1 m³/s

Analysis of the trajectories (Figure 5) of the particle motion shows that the bulk of the particles (more than 90%) under the action of inertial forces reach the opposite wall of the apparatus and then rises to the filtering layer. In this mode of operation, the efficiency of particle trapping does not exceed 60%.

To improve the filtration capacity of the apparatus, it is necessary to introduce changes in the design of the scrubber that will ensure a uniform load on the filter surface.

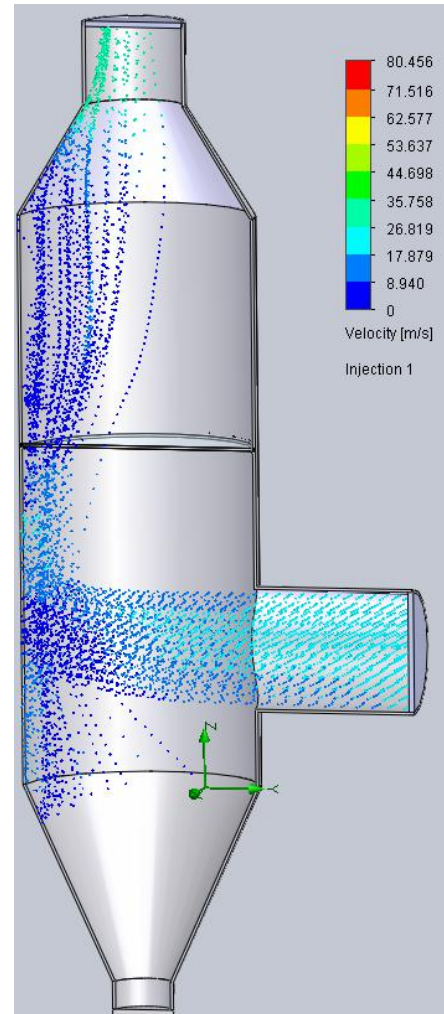

Fig. 5. The results of investigating the trajectories of quartz solid particles in the size of a scrubber.

To such changes it is possible to carry: the device of several inlet branch pipes; the device of a tangential inlet branch pipe; changing the aerodynamic mode of the apparatus; installation of additional devices inside the device to change the trajectories of the particles.

CONCLUSION

Numerical study of the scrubber will allow analyzing the scrubber operation in order to reduce energy consumption while maintaining the quality of gas cleaning.

The model helps to quickly and visually simulate the movement of a dusty gas stream taking into account the changes introduced into the geometry of the scrubber. Thus, the model can be used to optimize the scrubber design, depending on the type of production and the characteristics of the contaminated gas.

As a result, we can conclude that it is necessary to take into account the non-uniformity of the distribution of the

velocity fields in the subsequent process of simulating the purification and cooling of gas in the scrubber.

REFERENCE

- [1] Kropp L.I., Chekanov G.S., Khodakov Yu.S., Shmigol I.N., Development of the technology for flue gas cleaning at TPP / Heat power engineering, 1991, №6.
- [2] Afaniuk V.V., Spinov V. M., Patent No. 3615 Ukraine, IPC 7 V01D3 / 22. Vortex plate for heat-mass exchange machines / stated 30.12. 2003; published December 15, 2004, Bulletin №12.
- [3] Afaniuk V.V. Development of a vortex dish design for heat-mass transfer devices/ V.V. Afaniuk, V. M. Spinov // Bulletin of Odessa state academy construction and architecture. Odessa: ODABA, 2004. №13, pp. 12 - 15.
- [4] Loitsyansky L.G., Mechanics of fluid and gas. M.: Science, 1973. 847 p.
- [5] SolidWorks. Computer modeling in engineering practice / Alyamovskii A. A., Sobachkin A. A., Odintsov E. V., Kharitonovich A. I., Ponomarev N. .B - St. Petersburg: BHV-Petersburg, 2005. - 800 p.