



DESIGN AND CONTROL OF PLASTIC BOTTLE BREAKING AND STORAGE MACHINE

Sezgin ERSOY*, Ebuzer AYGUL, Ersin TOPTAŞ

Marmara University, Istanbul, Turkey

ARTICLE INFO

Article history:

Received 14 July 2017

Accepted 24 January 2018

Keywords:

bottle shredder machine, plastic shredder, mechatronic system, Industries

ABSTRACT

In this study we present a pet bottle shredder machine and mechatronic system used in machine. Plastic shredder is a machine used for cutting the plastic bottles in small pieces to make waste management easier. We are making this project for recycling of plastic bottle wastage in domestic area, industries etc. In this areas the plastic bottle waste is present in large quantity, but the availed machines used to recycle this waste, is not exist. Benefit of this machine is the recycle of the plastic bottles. In this machine, plastic bottles are detected with the pet sensor (Omron E3Z-B61-ECON (0.5M)) and shredded with shredder. This machine is controlled by Arduino Mega. The objects taken in the system are directed by Arduino. As a result of the separation process, the pet bottles sent to the crusher are divided into smaller pieces by means of an asynchronous motor and a crusher driven by an asynchronous motor. The result is a more efficient use of storage space. In this regard, the first steps of the recycling process, namely separation and crushing, will be done more effectively using the automation system than the conventional methods.

© 2018 Journal of the Technical University of Gabrovo. All rights reserved.

INTRODUCTION

According to the United Nations report, it is estimated that the world population will reach 8.1 billion by 2025 and the number of people living in cities until 2025, which is the result of rapid urbanization, will reach 2-3 times higher than today. Urbanization, which is a natural consequence of this rapid population growth, is not a problem in itself, but it causes many environmental problems such as random and unplanned growth, damage to public areas and rivers, air and water pollution and solid waste generation. [1]

In this context, humanity has to rely on alternative / renewable energy sources such as biomass, hydroelectric, geothermal energy, wind energy, solar energy and nuclear energy. On the other hand, an appropriate waste management strategy is another important aspect of sustainable development. In the last decade, the increase in the level of prosperity in the modern society has indirectly led to a large increase in the production of all kinds of waste producing products. Plastics are one of the fastest growing materials due to their wide application range, their versatility and relatively low cost. At the beginning of these are pet bottles made of polyethylene. [2]

In this regard, plastic beverage bottles containing gas permeable walls made of polyethylene terephthalate or "PET" have recently displaced other containers for carbonated beverages, especially in sizes of 1 litre and larger. The widespread use of these containers has created an important need for recycling methods. Many PET-walled beverage containers contain bottom caps or reinforcements made of relatively low cost polyolefin plastics such as high density polyethylene. [3]

Here, in order for the recycled materials to be transported back to the market, it is necessary to separate the polyolefin and pet plastic. At this point, local governments have begun to imagine solid waste sorting facilities to make these processes more effective.

Carlo Gulmini contributed to the collection of plastic bottles with the patent that he had in 1990s, performing one of the most basic of the studies for plastic recycling. Carlo Gulmini invented a machine for storing plastic bottles by means of an electric piston. [4]

In 2010, David Borowski-William Huddleston-Benjamin Thorp recycled paper, cardboard, and other waste into machines that they invented, distinguishing them from harmful liquids and making them usable again. [5]

Alexander Hamilton and Lewis-Gray used a rotating drum to separate metal items from a machine that was inspired by artificial magnetic energy, and when the drum was spinning, the metal items were pulled apart to attract metal. [6]

Maria Laura Mastellone, Raffaele Cremiato, has shown that solid wastes can be separated by solid separators in solid waste separation centers. As a result of the improvements made, it has been observed that the efficiency of the solid waste separation centers is increased. [7]

MATERIALS AND METHOD

In this study, the system was controlled using Arduino. As a result of the investigations, pet bottles made of polyethylene tetrafluoride are detected with Omron E3ZB 61 sensor and the pet bottles are sent to plastic breaker.

* Corresponding author. E-mail: sersoy@marmara.edu.tr

With the aid of a crusher, plastics are granulated to provide a volume advantage. When the project is carried out, what needs to be done will be examined in three categories as mechanical, electrical and software. In Figure 1, we have provided the chassis image we designed for our system. The parts and features of the numbered parts indicated on the figure are given below.

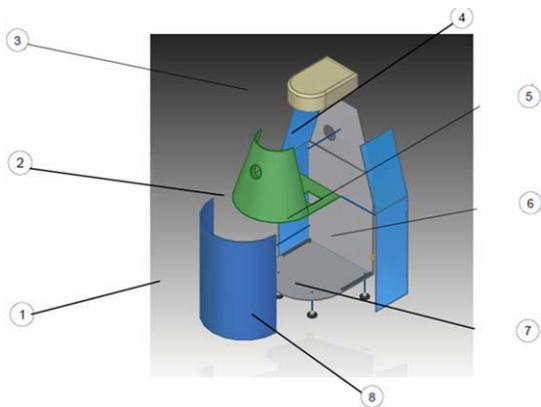

Figure 1. Exploded view of the case

The track number 1 shows the front part of the car. The part that is planned to be manufactured from aluminium is located at the front part. The number 2 area is one of the most basic parts of the machine. In this section, there is a hole where the pet bottles can be put into the machine. The height of this hole is set to 140 cm. The number 3 is the part of the underground machine which we call the new top cover. The number 4 area has a fixed back cover. Area 5 has the back door of the machine. Area 6 is the side of the machine. Area 7 refers to the rail laid on the base. The warehouse will move on these rails. Finally, the number 8 stands on the pedestal's pedestal

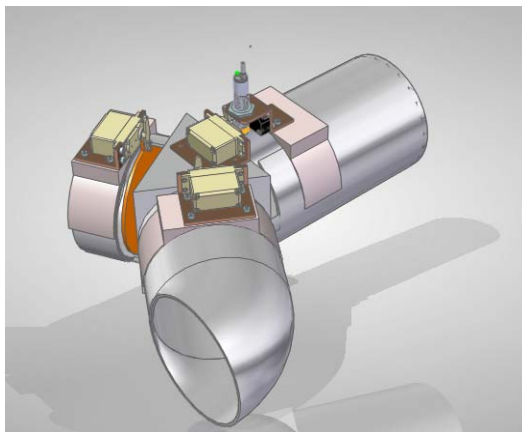

Figure 2. Decomposition system

In Figure 2 we have designed the decomposition system. All necessary mechanical and electrical components in the system shown in the figure are drawn and assembled in the SolidWorks program. The working principle of the decomposition system can be generalized as follows. First, the pet bottle is thrown out of the box, the capacitive sensor determines if it is plastic with the pet bottle sensor after it detects an object (ie does it really exist there?). Then if the thrown object is a plastic bottle, the corresponding lid is opened and the bottle crusher. It falls on it and the object is broken. As a result, if both the capacitive sensor and the bottle sensor are detected, the

object breaker is diverted. If the capacitive sensor senses the pet bottle sensor, it is routed to the garbage.

MECHANICAL PROBLEMS AND SOLUTIONS

In this section, mechanical problems and solutions will be mentioned. The mechanical problems encountered are as follows:

- Outside frame designs of the machine
- A decomposition system for decomposing objects
- Design of a crusher for less space for pet bottles
- Direct drive of the crusher with an asynchronous motor to drive the crusher
- A storage system for storing shattered pet bottles,

The Von Mises stress analysis in the region of the cutter mouth of the cutting tool resulting from the applied force on the cutting tool as follows

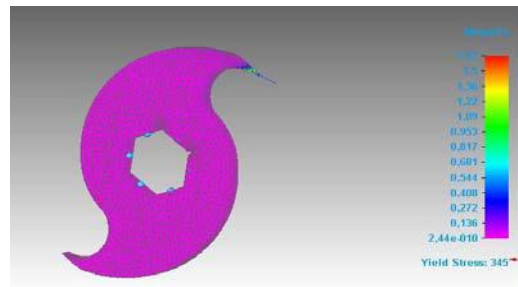

Figure 3. Maximum stress on blade

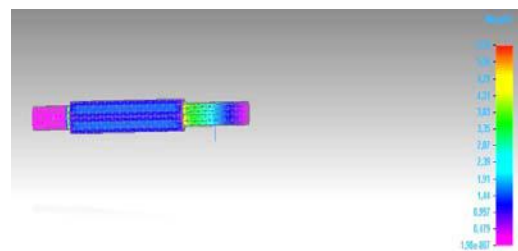

Figure 4. Maximum stress on the shaft

The torsional stress analysis on the shaft designed to move the blades on the crusher is as follows. Torsional analysis was carried out by applying 10 Nm of torque to the motor, which will operate under a maximum force of 6 Nm.

SYSTEM CONTROL

System control must be done correctly and smoothly for proper control and inspection of the system and for providing internal and external safety in the system. On the contrary, very important problems may be encountered in the system.

Several different control structures have been considered for the system control to be determined in the course of the creation of the system prototype. The general structure for system control is the same for all systems, only the control elements vary. It is planned to use arduino control cards as the controller when the system is prototyped. Due to its affordability, easy programming, and the availability of large open source libraries, arduino control cards have become popular in recent years and are beginning to be used on almost all projects. Because of these features, our first choice for system control is designated as arduino control cards.

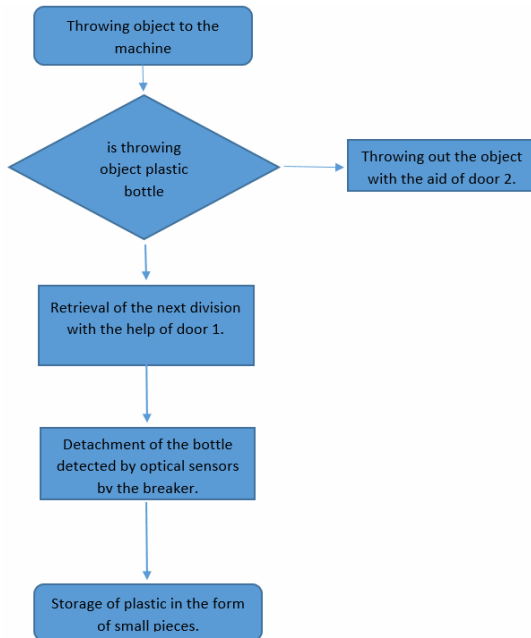

Figure 5. System control scheme

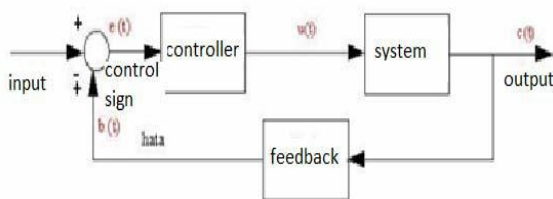

Figure 6. System control diagram

CONCLUSION

As a result of the designs, it has been understood that the plastic bottles which will not dissolve in nature for thousands of years and damage the environment can be collected for recycling using an automation system. Thanks to this study, it has been calculated that not only environmental rehabilitation but also economical rehabilitation will be made by contributing to the recycling of plastic bottles.

As a result of the designs made, the pet bottles taken into the system will take up very little space because they are broken. However, the use of a crusher and asynchronous motor to break pet bottles into the system, and the sensor used to detect the plastics being plastics, caused a very high cost. Arduino, a development card, was used instead of using plc when controlling the machine. The use of Arduino is the high cost of PLCs. As a result of all the research done, besides the damage caused by the plastic bottles to the nature, the cost to be made by this machine is very insignificant.

ACKNOWLEDGEMENTS

This work has been supported by Marmara University Technology Faculty.

REFERENCE

- [1] Doç.Dr.Abdullah YILMAZ, Dr.Yavuz BOZKURT, 2010, Urban Solid Waste Management Practices in Turkey and Kütahya Solid Waste Association (KÜKAB) For example, Süleyman Demirel University Journal of Faculty of Economics and Administrative Sciences Y.2010, C.15, S.1 s.11-28.
- [2] Achyut K. Pandaa, R.K. Singha, D.K. Mishrab, Thermolysis of waste plastics to liquid fuel: A suitable method for plastic waste management and manufacture of value added products—A world prospective, 16 April 2009.
- [3] Benjamin R. Hannigan, Jose R. Fernandes , Plastics separation and recycling methods, 16 May 1989.
- [4] Carlo Gulmini, Unit for collecting and recyclin used bottles, cans and similar in metal and plastic materials, 28 March 1989.
- [5] David Borowski, William Huddleston, Benjamin Thorp, Waste Recycling Systems, Processes, and Methods, 9 September 2009.
- [6] Alexander Hamilton Lewis-Gray, Magnetic separation method, 24 Ağu 2004.
- [7] Maria Laura Mastellonea, Raffaele Cremiatoa, Lucio Zaccarielloa, Roberta Lotitoa, Evaluation of performance indicators applied to a material recovery facility fed by mixed packaging waste, 26 February 2017.